

**MODELO: DRY**



**CARACTERISTICAS**

Construido en acero inox. AISI 304  
Certificación CE  
Cinta motorizada con velocidad regulable  
Bandeja de recogida de agua  
Fotocélula de arranque automático

**PESO**

300 Kg. Aprox.

**ELECTRICIDAD**

Voltaje 400 V  
Fases 3P+N+Tierra  
Frecuencia 50/60 Hz  
Potencia máxima

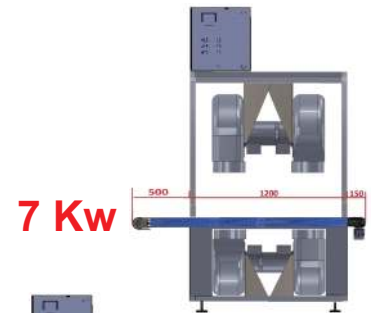
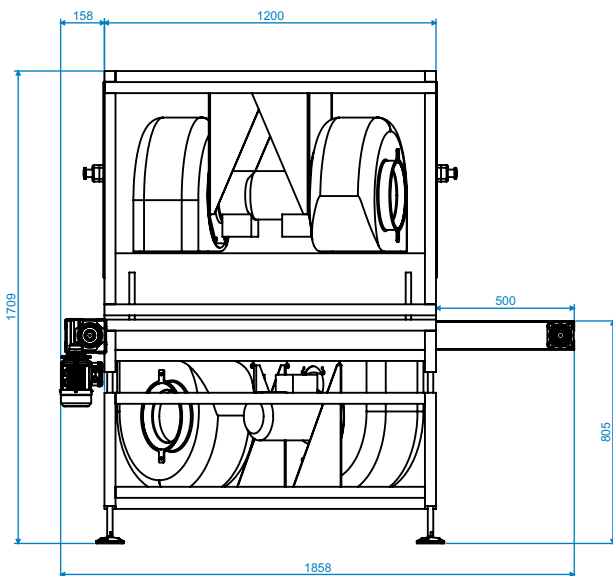

**7 Kw**

**13 Kw**

